

## FEATURED ITEMS IN ENGINE COMPONENTS

### Billet Specialties Pulley System Packages

Engine Components

#### Tru-Trac Serpentine BONUS Systems

BS13220 **\$2195.00**  
*Small Block Chevy with A/C and Power Steering  
 Includes a \$145 Billet Specialties Remote PS  
 Reservoir at no extra cost!*

BS13220 **\$2295.00**  
*Big Block Chevy with A/C and Power Steering  
 Includes a \$145 Billet Specialties Remote PS  
 Reservoir at no extra cost!*

#### Tru-Trac Serpentine Standard Systems - FREE SHIPPING!

BS13120 **\$1845.00**  
*Small Block Chevy with A/C, no Power Steering*

BS13225 **\$1795.00**  
*Small Block Chevy with Power Steering, no A/C*

BS13125 **\$1435.00**  
*Small Block Chevy no A/C, no Power Steering*

BS14120 **\$1945.00**  
*Big Block Chevy with A/C, no Power Steering*

BS14225 **\$1895.00**  
*Big Block Chevy with Power Steering, no A/C*

BS14125 **\$1535.00**  
*Big Block Chevy no A/C, no Power Steering*

#### V-Trac V-Belt Systems - FREE SHIPPING!

BSV3220 **\$1395.00**  
*Small Block Chevy with A/C and Power Steering*

BSV3120 **\$1195.00**  
*Small Block Chevy with A/C, no Power Steering*

BSV4220 **\$1495.00**  
*Big Block Chevy with A/C and Power Steering*

BSV4120 **\$1295.00**  
*Big Block Chevy with A/C, no Power Steering*

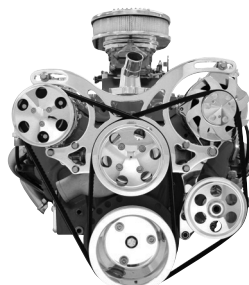

**Complete Packages Include:** polished billet aluminum crankshaft pulley, power steering pulley, alternator fan and pulley, water pump and tensioner pulleys, polished billet aluminum tensioner, polished billet aluminum bridge bracket, Edelbrock reverse rotation water pump, polished Sanden SD-7 compressor, polished billet aluminum compressor cover and manifold, Maval power steering pump with AN fittings, Powermaster 105 amp 1-wire alternator, ARP polished stainless fasteners, and Goodyear Gatorback Poly Serpentine or V-groove belt.

Visit our online store for even more product selection!

[www.hotrodexpress.com](http://www.hotrodexpress.com)

Visit our online store for even more product selection!

[www.hotrodexpress.com](http://www.hotrodexpress.com)



**Billet Specialties Serpentine Tru-Trac Ford® Systems FREE SHIPPING!**

All Tru-Trac systems are now also available with a black anodized finish. Call for more information and pricing.

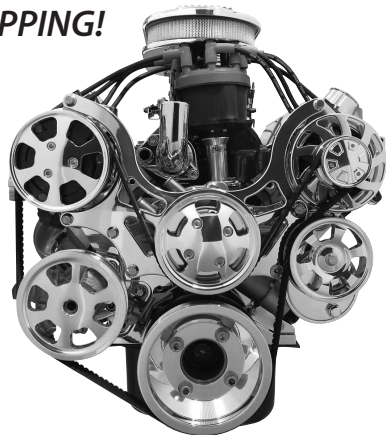

PART	ENGINE	A/C	PS	PRICE
BS13600	SB Ford	Yes	Yes	\$2295.00
BS13620	SB Ford	Yes	No	\$1945.00
BS13605	SB Ford	No	Yes	\$1895.00
BS13625	SB Ford	No	No	\$1545.00

**OTHER APPLICATIONS**

Big Block Ford	starting at	\$1795.00
Ford FE	starting at	\$1745.00
HEMI/Big Block Chrysler	starting at	\$2145.00
Small Block Chrysler	starting at	\$1745.00
Chevy LS1, LS2, LS6	starting at	\$1745.00

Engine Components

**Hyperdrive™ V-Belt Systems for Chevrolet® FREE SHIPPING!**

PART	ENGINE	A/C	PS	PRICE
TBI6200	Big Block	Yes	No	\$1325.00
TBI6207	Big Block	Yes	Yes	\$1395.00
TBI6100	Small Block	Yes	No	\$1325.00
TBI6107	Small Block	Yes	Yes	\$1395.00

Precision CNC-machined, fully polished, all-aluminum V-belt mount and drive system. Mounts the compressor and alternator using the water pump bolts. Kits include 140 amp alternator, Sanden SD-7 compressor, compressor clutch cover, compressor hardlines, mounting brackets, polished aluminum high flow water pump, pulleys, belts, chrome mounting hardware, and GM Type II power steering pump.



**Vintage Air Front Runner™ Serpentine Pulley Systems for Chevrolet® and Ford® FREE SHIPPING**



PART	ENGINE	A/C	PS	FINISH	PRICE
VA175010-SCA	SB Chevy	Yes	No	Hardcoat	\$1660.00
VA174010-SCA	SB Chevy	Yes	Yes	Hardcoat	\$1685.00
VA175020-SCA	SB Chevy	Yes	No	Bright	\$1810.00
VA174020-SCA	SB Chevy	Yes	Yes	Bright	\$1835.00
VA175050-BCA	BB Chevy	Yes	No	Hardcoat	\$1775.00
VA174050-BCA	BB Chevy	Yes	Yes	Hardcoat	\$1800.00
VA175060-BCA	BB Chevy	Yes	No	Bright	\$1925.00
VA174060-BCA	BB Chevy	Yes	Yes	Bright	\$1950.00
VA175102-SFA	SB Ford	Yes	No	Hardcoat	\$2100.00
VA174102-SFA	SB Ford	Yes	Yes	Hardcoat	\$2200.00
VA175103-SFA	SB Ford	Yes	No	Bright	\$2150.00
VA174103-SFA	SB Ford	Yes	Yes	Bright	\$2250.00

Depending on hardcoat or bright package, typical complete kits include anodized or machine finish bracket, hard coat or chrome pulleys, standard or polished finish compressor with hardlines, natural or polished finish 140 amp alternator, water pump, stainless 5/8" extended heater hose nipple, hardware, and belt.

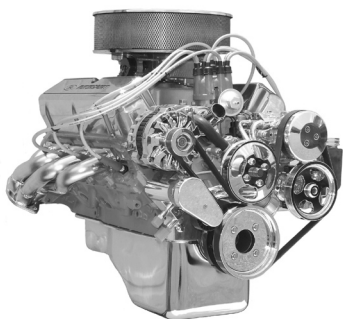

704-483-3300



## Billet Specialties Water Pump Pulleys



### Long Water Pump Applications

*Small or Big Block Chevrolet*

BS78110	1-groove	\$69.95
BS78120	2-groove	\$69.95
BS84220	Nose Cone	\$15.95

### Short Water Pump Applications

*Small or Big Block Chevrolet*

*Small Block Applications*

BS80120	1-groove	\$74.95
BS80220	2-groove	\$74.95
BS84120	Nose Cone	\$15.95

*Big Block Applications*

BS82120	1-groove	\$74.95
BS82220	2-groove	\$74.95
BS84120	Nose Cone	\$15.95

## Billet Specialties Crankshaft Pulleys



### Long Water Pump Applications

*Small or Big Block Chevrolet*

*Small Block Applications*

BS78210	1-groove	\$64.95
BS78220	2-groove	\$64.95
BS78320	3-groove	\$69.95

*Big Block Applications*

BS79210	1-groove	\$64.95
BS79220	2-groove	\$64.95
BS79320	3-groove	\$69.95

### Short Water Pump Applications

*Small or Big Block Chevrolet*

*Small Block Applications*

BS81120	1-groove	\$59.95
BS81220	2-groove	\$64.95
BS81320	3-groove	\$69.95

*Big Block Applications*

BS83120	1-groove	\$59.95
BS83220	2-groove	\$64.95
BS83320	3-groove	\$69.95

## Billet Specialties 1-Piece Alternator Pulley w/ Fan



Polished billet aluminum with a bolt-on nose cone and stainless hardware included.

BS85220 **\$54.95**

## Chrome GM Alternator



GMA1	\$125.00
<i>1-wire 100 amp</i>	
GMA3	\$99.00
<i>3-wire 100 amp</i>	
LGMA	\$189.00
<i>Late GM 140 amp</i>	

## Billet Specialties A/C Clutch Cover - Sanden 508



Solid polished billet aluminum, bolts directly to the Sanden 508 clutch with stainless hardware.

BS87120 **\$39.95**

## GM Factory Steel Pulleys for Small Block Chevrolet®

*Powder-coated black finish for short water pump applications.*



GM22502-VCA	<i>Power Steering 2-groove</i>	<b>\$65.00</b>
GM22503-VCA	<i>Water Pump 2-groove</i>	<b>\$70.00</b>
GM22506-VCA	<i>Crankshaft 2-groove</i>	<b>\$52.00</b>
GM22507-VCA	<i>Add-On to create 3-groove Crankshaft pulley</i>	<b>\$48.00</b>

**RPC Pulleys for Chevrolet®**



**Crankshaft Pulleys**

**Short Water Pump Applications**

*Small Block Chevy Applications*

RPC9602	1-groove	\$20.00
RPC9603	2-groove	\$25.00
RPC8963	3-groove	\$45.00

*Big Block Chevy Applications*

RPC9816	2-groove	\$30.00
RPC9817	single add-on	\$25.00

**Long Water Pump Applications**

*Small Block Chevy Applications*

RPC9607	2-groove	\$40.00
RPC9608	3-groove	\$40.00

**Water Pump Pulleys**

**Short Water Pump Applications**

*Small Block Chevy Applications*

RPC9600	1-groove	\$20.00
RPC9601	2-groove	\$25.00

*Big Block Chevy Applications*

RPC9815	2-groove	\$25.00
---------	----------	---------

**Long Water Pump Applications**

*Small Block Chevy Applications*

RPC9604	1-groove	\$20.00
RPC9605	2-groove	\$25.00

**Power Steering Pulleys - GM**

RPC8948	keyed 1-groove	\$20.00
RPC8947	keyed 2-groove	\$25.00

**Billet Specialties**

**Power Steering Pulleys**



Designed to work with Saginaw power steering pumps with a built-in reservoir. Machined billet aluminum with a mirror polish finish. Keyway pulleys for long or short water pump applications, press-on pulleys for long only.

*Keyway V-Belt*

BS86120	1-groove	\$59.95
BS86220	2-groove	\$64.95
BS1030PC	Serpentine	\$69.95

*Press-On V-Belt*

BS86420	1-groove	\$59.95
BS86520	2-groove	\$64.95
BS1035PC	Serpentine	\$69.95

**Billet Specialties**

**Remote Power Steering Reservoirs**



Includes male AN fittings on the bottom of the reservoir and self-clamping bracket.

BS77910	\$144.95
<i>Smooth Reservoir w/ Bracket</i>	
BS77920	\$144.95
<i>Ribbed Reservoir w/ Bracket</i>	

**Polished Billet Power Steering Reservoirs**



Designed to fit GM Type II power steering pumps. The reservoir mounts with factory clips and uses -6AN inlet fitting. A remote mount design is also available, measuring 6" x 3" with a -6 AN inlet fitting and a -10 AN outlet fitting. **On pump reservoir requires Type II pump with pressed-in return fitting.**

TBI6100BRP	<i>Fits GM Type II Pumps (Alum.)</i>	\$165.00
TBI6100P-1	<i>Remote Mount Design (Alum.)</i>	\$115.00
PSTYPIIPR	<i>Fits GM Type II Pumps (Plastic)</i>	\$60.00

## Tuff Stuff Chrome Saginaw Power Steering Pump



Keyed pulley not included with pump.

TSCSPSP \$149.00



## GM Starters

Chrome gear reduction - SB or BB, 153 or 168 tooth flywheels \$200.00

Plain gear reduction - SB or BB, 153 or 168 tooth flywheels \$145.00

Chrome Hi-Torque - SB with 168 tooth flywheels, staggered bolt pattern \$155.00

## Pertronix Electronic Ignition



PT1181	'57-'74 Chevy 8cyl	\$79.95
PT4001	Flame Thrower	\$45.00
	1.5 ohm Chrome	
PT40011	Flame Thrower	\$45.00
	1.5 ohm Black	



## Sun Specs Exhaust Hangers

Polished billet aluminum 2-piece hangers. 4-1/2" hanger drop.

SSEH2	2" exhaust	\$80.00 pair
SSEH225	2-1/4" exhaust	\$80.00 pair
SSEH25	2-1/2" exhaust	\$85.00 pair

## Pete and Jake's Mounts



### Model A Motor Mounts

Mounts small block Chevy or Ford motors using factory type rubber side mounts. Fits boxed A rails or 2" x 4" repro frame rails.

PJ2005	Small Block Chevy	\$71.00
PJ2006	Small Block Ford	\$71.00

## Chassis Engineering Mounts

Frame adapters are 3-5/8" long and trim to fit. Please ask about vehicle specific motor mount kits.



CECS	Cushion Set	\$25.00
CEEM	Engine Mount	\$40.00
CEFA	Frame Adapter	\$25.00

## Polished Alum. Vacuum Fittings



VP-2	2-port fitting	\$27.00
------	----------------	---------

## Polished Stainless Pipe Plugs



SPP18	1/8"	\$4.00
SPP14	1/4"	\$4.00
SPP38	3/8"	\$6.00
SPP12	1/2"	\$8.00
SPP34	3/4"	\$10.00

## Chrome Hose Fittings



Straight 5/8" hose x 1/2" pipe	\$11.00
Straight 3/4" hose x 1/2" pipe	\$11.00
Straight 3/8" hose x 1/4" pipe	\$6.00
St. Long 5/8" hose x 1/2" pipe	\$19.00
St. Long 3/4" hose x 1/2" pipe	\$19.00
90° 5/8" hose x 1/2" pipe	\$14.00
90° 3/4" hose x 1/2" pipe	\$17.00
90° 3/8" hose x 3/8" pipe	\$11.00
90° 3/8" hose x 1/4" pipe	\$11.00



**Billet Specialties Independent Mount Brackets**

Engine Components



**Top Mount Vortec™ Heads  
Short Water Pump  
Small Block Chevrolet®**

- BS10721      \$135.95  
*Compressor Bracket*
- BS10720      \$135.95  
*Alternator Bracket*

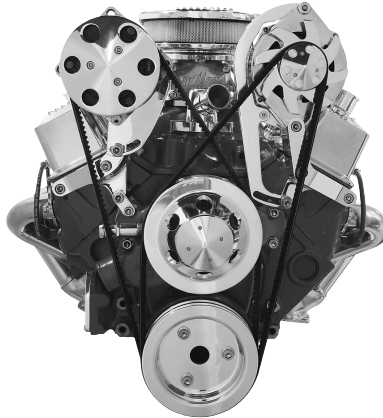

**Top Mount Standard Heads  
Short Water Pump  
Small Block Chevrolet®**

- BS10221      \$114.95  
*Compressor Bracket*
- BS10220      \$114.95  
*Alternator Bracket*

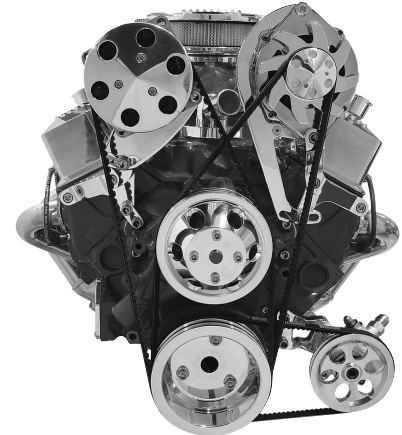

**Top Mount Standard Heads  
Long Water Pump  
Small Block Chevrolet®**

- BS11221      \$135.95  
*Compressor Bracket*
- BS11220      \$135.95  
*Alternator Bracket*

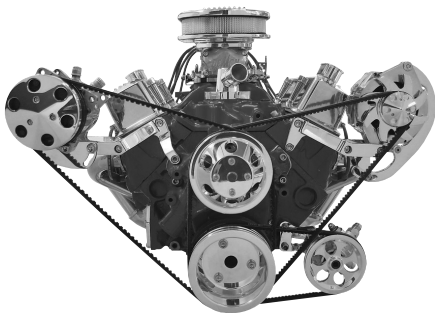

**Side Mount Standard Heads  
Short & Long Water Pump  
Small Block Chevrolet®**

- BS10421      \$135.95  
*SWP Compressor Bracket*
- BS10420      \$135.95  
*SWP Alternator Bracket*
- BS11421      \$135.95  
*LWP Compressor Bracket*
- BS11420      \$135.95  
*LWP Alternator Bracket*

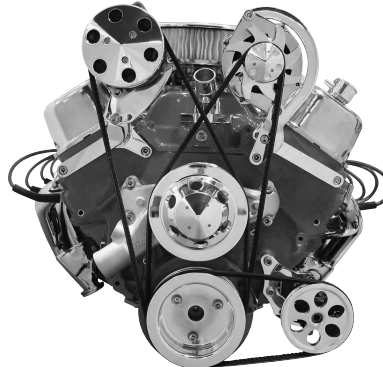

**Top Mount Standard Heads  
Short Water Pump  
Big Block Chevrolet®**

- BS10521      \$135.95  
*Compressor Bracket*
- BS10520      \$135.95  
*Alternator Bracket*

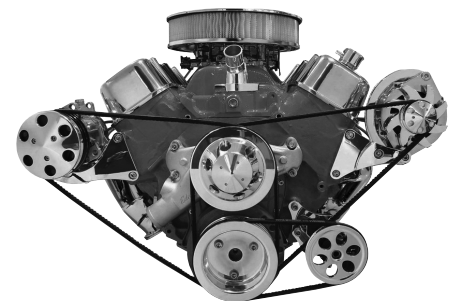

**Side Mount Standard Heads  
Short Water Pump  
Big Block Chevrolet®**

- BS10621      \$135.95  
*Compressor Bracket*
- BS10620      \$135.95  
*Alternator Bracket*

## Alan Grove Street Rod Style Brackets

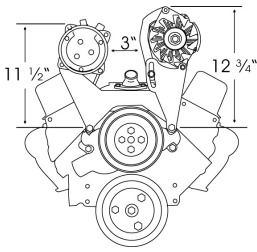

**For Short Water Pump Small Block Chevy**  
Bolt to top water pump and the two front intake bolts. Will clear tall valve covers with no drilling or tapping required.

AG100R	A/C bracket (Passenger)	\$85.00
AG100L	A/C bracket (Driver)	\$85.00
AG200L	Alt. bracket (Driver)	\$75.00
AG200R	Alt. bracket (Passenger)	\$75.00

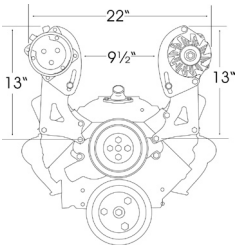

**For Vortec Small Block Chevy**  
Designed for '87 and later cast iron heads including the popular Vortec cast iron heads. Vortec

heads use 5/16" intake bolts that point straight down. Will clear valve covers up to 3" tall.

AG129R	A/C Vortec (Passenger)	\$85.00
AG228L	Alt. Vortec (Driver)	\$85.00

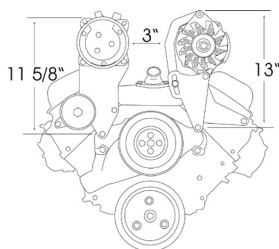

**For Short Water Pump Big Block Chevy**  
Bolts to the heads and top water pump locations. A/C bracket is complete with idler assembly. Will clear most valve covers.

AG104R	A/C bracket (Passenger)	\$85.00
AG204L	Alt. bracket (Driver)	\$70.00

## Alan Grove Low Profile Brackets

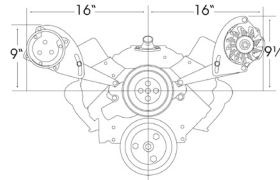

**For Short Water Pump Small Block Chevy**  
These brackets bolt to the water pump and exhaust. No holes needed in head.

Furnished with hardware to fit stock exhaust manifolds and most headers. If used with headers, the front tube must turn down enough to allow access to the bolt hole in front of the second pipe.

AG113R	A/C bracket (Passenger)	\$85.00
AG113L	A/C bracket (Driver)	\$85.00
AG213L	Alt. bracket (Driver)	\$85.00
AG213R	Alt. bracket (Passenger)	\$85.00

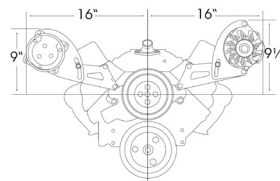

**For Short Water Pump or Vortec Small Block Chevy**  
These brackets bolt to the head and top water pump bolt holes. Brackets mount to

the head, requiring bolt holes. Standard alternator bracket will fit '69 and newer heads. Vortec-style brackets designed for '87 and later cast iron heads including the popular Vortec cast iron heads.

AG132R	A/C bracket (Passenger)	\$85.00
AG232L	Alt. bracket (Driver)	\$75.00
AG133R	A/C Vortec (Passenger)	\$85.00
AG233L	Alt. Vortec (Driver)	\$85.00

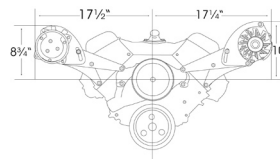

**For Short Water Pump Big Block Chevy**  
Designed for low hood applications. Works great on

any vehicle with a wide engine compartment. Bolts to the heads and water pump.

AG118R	A/C bracket (Passenger)	\$85.00
AG118L	A/C bracket (Driver)	\$85.00
AG218L	Alt. bracket (Driver)	\$85.00
AG218R	Alt. bracket (Passenger)	\$85.00

### Alan Grove Power Steering Brackets

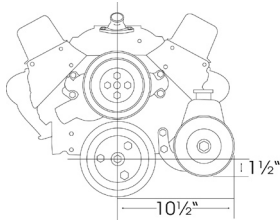

**For Short Water Pump  
Small Block Chevy**  
Designed for the Chevrolet® Saginaw non-metric power steering pump with the attached reservoir.

AG400L PS bracket \$65.00

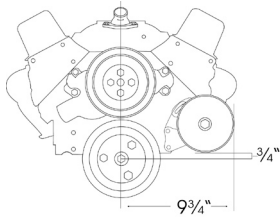

**For Short Water Pump  
Small Block Chevy  
Type II Pump - Street Rod**  
Designed to be used with the metric GM remote reservoir type 2 pump.

Sits high enough to clear most chassis parts and steering gears. Will not work with low profile brackets.

AG409L PS bracket \$65.00

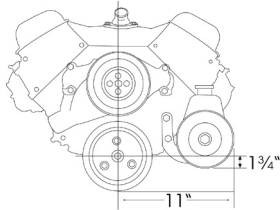

**For Short Water Pump  
Big Block Chevy  
Early Saginaw**  
Designed for the Chevrolet® Saginaw non-metric power steering pumps with the attached reservoir. They allow clearance for the alternator belt no matter where the alternator is mounted.

AG403L PS bracket \$65.00

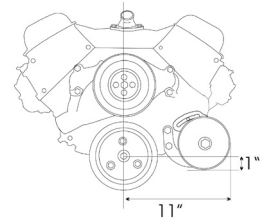

**For Short Water Pump  
Big Block Chevy  
Type II Pump -Low Profile**  
Designed to be used with the metric GM remote reservoir type 2 pump. Designed for low profile applications, it sits low enough to clear low profile alternator belt.

AG415L PS bracket \$65.00

### Alan Grove Low Mount Brackets

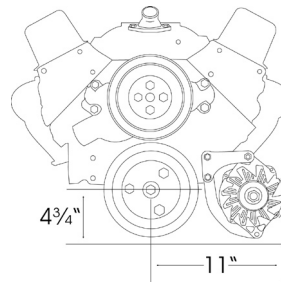

**For Short Water Pump  
Small Block Chevy**  
This brackets mount the alternator low on the driver or passenger side. Passenger side bracket requires the use of a remote fuel pump and some space below the front of the engine.

AG206L \$60.00  
Alt. short pump (Driver)  
AG211R \$60.00  
Alt. short pump (Passenger)

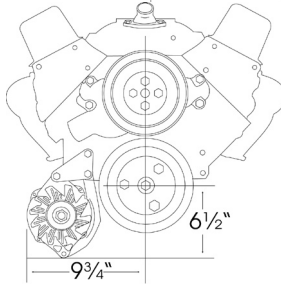

### Alan Grove Low Compressor Brackets

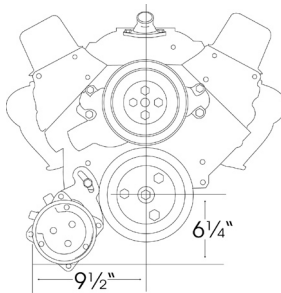

**For Short Water Pump  
Small Block Chevy**  
Tight-fit design fits narrow frames. Compressor bolts to fuel pump mounting flange for strength. May be driven off crank and fan pulleys or crank pulley only. Requires use of a remote fuel pump.

AG106R Comp. short pump \$65.00

### Alan Grove Small Block Ford® Brackets

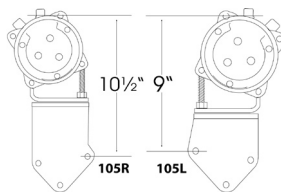

This bracket accommodates for a wide variety of timing cover, water pump, and pulley combinations on the Ford® small block. The compressor can be adjusted front to rear to align with the water pump and crank pulleys. Bolts to the driver's side head. Will fit 209, 302, and 351W engines.

AG105L A/C bracket \$90.00  
AG105R A/C bracket \$90.00



**Sanderson Headers**



**SB Chevy Blockhuggers**

Fits most '27-'48 cars and trucks, and many '49+ makes and models. Features 1-1/2" tubes and 2-1/2" collector.

SHCC1 Plain \$175.00  
SHCC1C Coated \$325.00



**SB Chevy Blockhuggers**

Fits most '27-'48 cars and trucks, and many '49+ makes and models. New design LS1 heads places the collector slightly off-center

SHCC1LS1 Plain \$285.00  
SHCC1LS1C Coated \$465.00

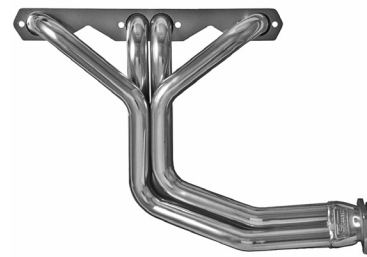

**SB Chevy Full Length**

'30-'41 cars and trucks; '49-'54 Chevy cars and '53+ Ford F100s. Fits tight to the block and exits a half-inch higher than the oil pan for great ground clearance. Straight plugs only. Includes all hardware for installation.

SHC3 Plain \$345.00  
SHC3 Coated \$535.00

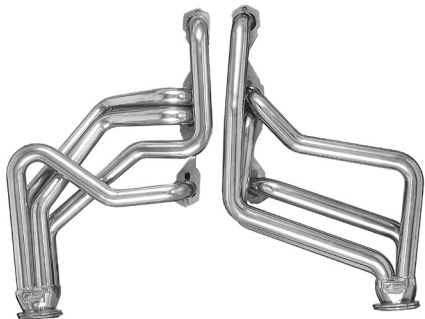

**SB Chevy Full Length**

Early Chevelles, El Caminos, and Malibus. Full length design for early Chevelle and Malibu features 1-3/4" tubes and 3" collectors for high RPM engines.

SHC12 Plain \$285.00  
SHC12C Coated \$435.00

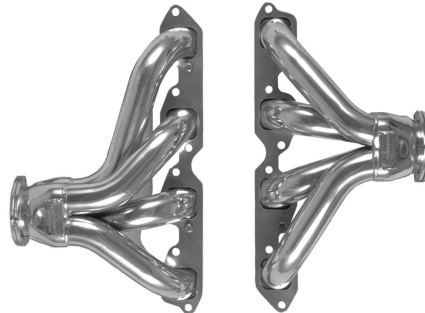

**BB Chevy Blockhuggers**

'32-'48 cars and trucks; '55-'63 Chevy cars; '49-'54 Chevy; '48+ Ford pickups. Constructed of 1-7/8" primary tubes and a 3" collector. Fits 396-454 engines in '32-'50 cars and some late models. Includes all hardware.

SHBB1 Plain \$265.00  
SHBB1C Coated \$415.00

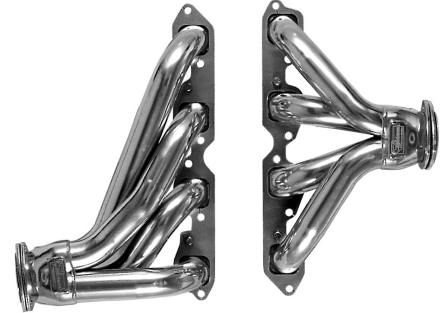

**BB Chevy Nova Blockhuggers**

'62-'67 Chevy Novas. Designed for 396-502 blocks in early Novas, with big 1-7/8" tubes and 3" collectors. Includes all hardware. *Note: For use in cars with rack-and-pinion or other steering conversions that eliminate the shock towers.*

SHBBNOVA Plain \$315.00  
SHBBNOVAC Coated \$465.00

**Sanderson Headers, cont.**

Engine Components



**BB Chevy Full Length**

'32-'48 cars and trucks. A proven performer, recently redesigned for more ground clearance. C5s can also now be used with any front or side motor mounts. Work well with either Mustang cross steering or rack and pinion.

SHC5	Plain	\$355.00
SHC5C	Coated	\$545.00

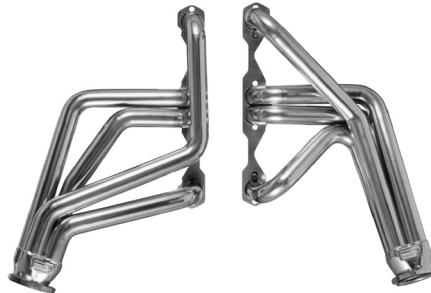

**SB Tri-5 Chevy Full Length**

Clears both manual and GM 605 power steering. Fits all Chevy small blocks from 265-400 cu. in., including the HO and ZZ motors.

SHC56	Plain	\$335.00
SHC56C	Coated	\$495.00



**BB Tri-5 Chevy Full Length**

Works with either stock or 605 steering. Fits all iron heads and clears side or front motor mounts. Both sides are shorter than the oil pan for great ground clearance.

SHBB55	Plain	\$355.00
SHBB55C	Coated	\$545.00

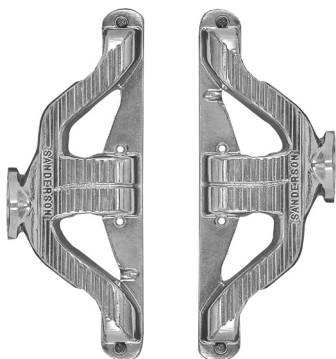

**SB Tri-5 Chevy Blockhugger**

One piece design featuring D-port configuration and anti-reversion baffles for both low end torque and top end horsepower. The parallel ribs dress up any engine!

SHQP1000	Plain	\$335.00
SHQP1000C	Coated	\$495.00

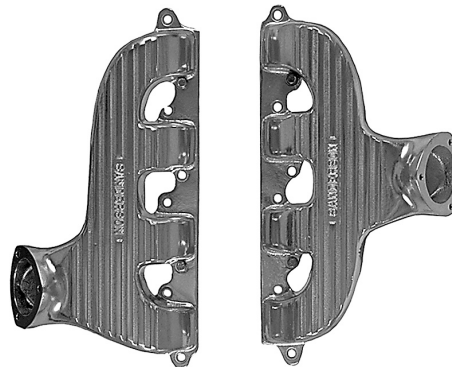

**BB Tri-5 Chevy Blockhugger**

Big Block cast series header with D-port and anti-reversion technologies.

SHQP2000	Plain	\$450.00
SHQP2000C	Coated	\$610.00

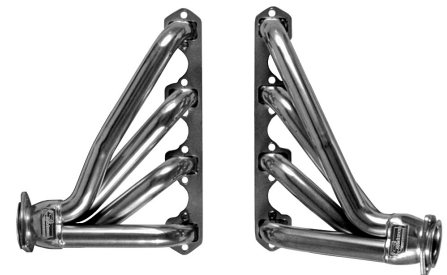

**SB Ford Windsor Blockhugger**

'35-'40 cars and trucks; '63+ Ford F100 pickups. Newer style for the small block Ford in '32 and newer chassis. It works well with any rack and pinion, Mustang, or Vega steering setup. Includes all hardware.

SHFF2	Plain	\$265.00
SHFF2C	Coated	\$415.00